

Wood chip boiler

thermiⁿator II touch



- ✓ Powerful products
- ✓ Modern design
- ✓ Low emissions

Wood chips



+



Log wood



Wood gasification technology

- ✓ Stainless steel filling chamber
- ✓ Lambda sensor technology since 1981!
- ✓ Our experience is your advantage!

SOLARFOCUS

Comfort starts with heating!

Comforting – when the



fuel grows just outside the front door!

thermiⁿator II touch –
perfect for wood chips and log wood

- Efficiency with wood chips: up to **93,3 %**
Efficiency with log wood: up to **94,4 %**
- Intuitive 7" touchscreen display
- Minimal power consumption
- Requires only 230 V of power supply
- Power range: 30, 40, 49 and 60 kW



Applications

- ✓ New bulidings
- ✓ Single- and multi-family houses
- ✓ Hotel business, Industry and Commerce

30 years experience in the development of wood burning boilers provides you with a perfectly proven product!

Wood chips

- ✓ from the region
- ✓ for the region
- ✓ independence for generations

SOLARFOCUS is shaping the future with products to serve mankind and conserve the environment!
Wood chips are a by product of domestic forestry and forest management. This fact makes them into a favourable alternative to fossil fuels.



30 years of experience with biomass heating

Biomass - energy from “stored solar energy”

In contrast to fossil fuels, wood as a combustible energy source releases almost no sulphur and is CO₂-neutral.

Heating as part of the natural cycle

The CO₂ released from burning wood is used to create new biomass. Hence the use of wood as an energy source is a worthwhile contribution to the ecological closed-loop economy.

Wood - local energy

The farmer as energy supplier. Every year, through sustainable cultivation of domestic forests, a third more wood grows back than we use.



Your benefit

- no dependence on imports
- crisis-proof
- supports local value creation

Wood chips

All types of thinning material are suitable for use as wood chips, but also untreated waste wood and off-cuts from the wood-processing industry. To be able to burn wood chips as efficiently as possible and free from problems, the water content must be kept low.

Fuel specification for wood chips

Fuel specification: W 30 to ÖNORM M 7133

1 kg wood chips has a calorific value of approx.	3.3 - 4.2 kWh
The weight of 1 m ³ of wood chips	approx. 170 - 280 kg
Water content	max. 30 %



Optimum water content is between 17% and 25%

Important: With a higher water content, the energy yield falls dramatically as the resulting steam energy escapes unused through the chimney.

✓ **Technology and combustion principle behind the thermiⁿator II touch wood chip boiler**
Metered combustion to achieve burning of wood chips with unsurpassed combustion quality. Even when operated at partial loads, the thermiⁿator II touch achieves excellent emission values.

✓ **Air supply**

The lambda-controlled secondary air-mixture achieves the highest possible efficiency, even when burning different types of wood chip.

✓ **Downfiring combustion technology**

The unique feature of the downfiring technology is that the burning flame points downwards. The fire bed (1) is not disturbed. The methane gas from the fuel is released into the patented, hopper shaped chromium steel crucible (2) (wood gasification) and the burning methane gas is sucked through the boiler by the speedregulated ID fan. Temperatures of up to 1,200 °C (6) are created in the combustion chamber. This ensures that the fuel is completely combusted. The final residues of combustible items, in the ash (7) are also burnt.

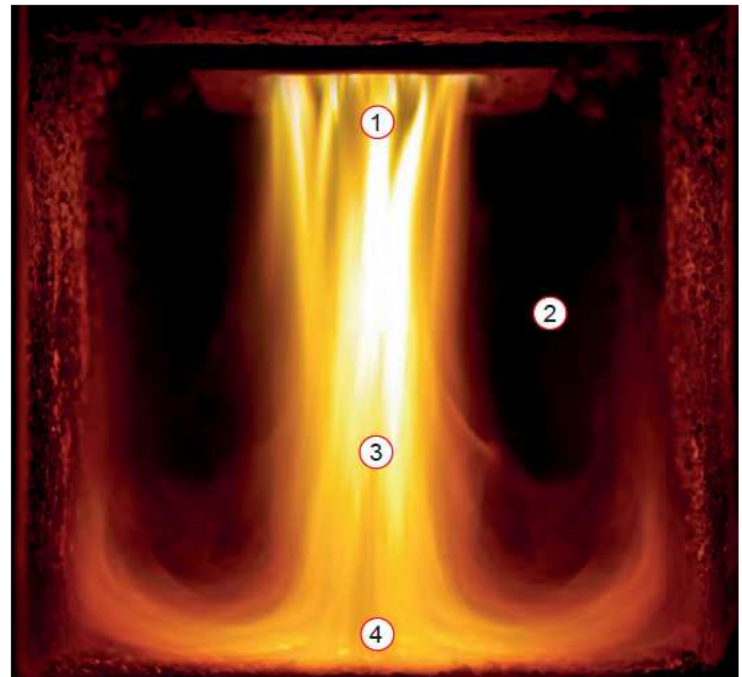

Wood gasification technology

Your benefit

- Firing control optimises the burner automatically.
Firing control optimises the burner automatically.
- The downburn technology guarantees optimum fuel usage,
NO moving parts in the combustion chamber,
NO charred fuel-residues remain in the ashes.
- Compact, space-saving construction
- Independently tested for both operating modes
(log wood + wood chips)
- 30 years of experience in lambda sensor technology



Sophisticated technology in detail

Also perfectly suitable for log wood!

Efficiency with wood chips: up to 93,3 %

Efficiency with log wood: up to 94,4 %

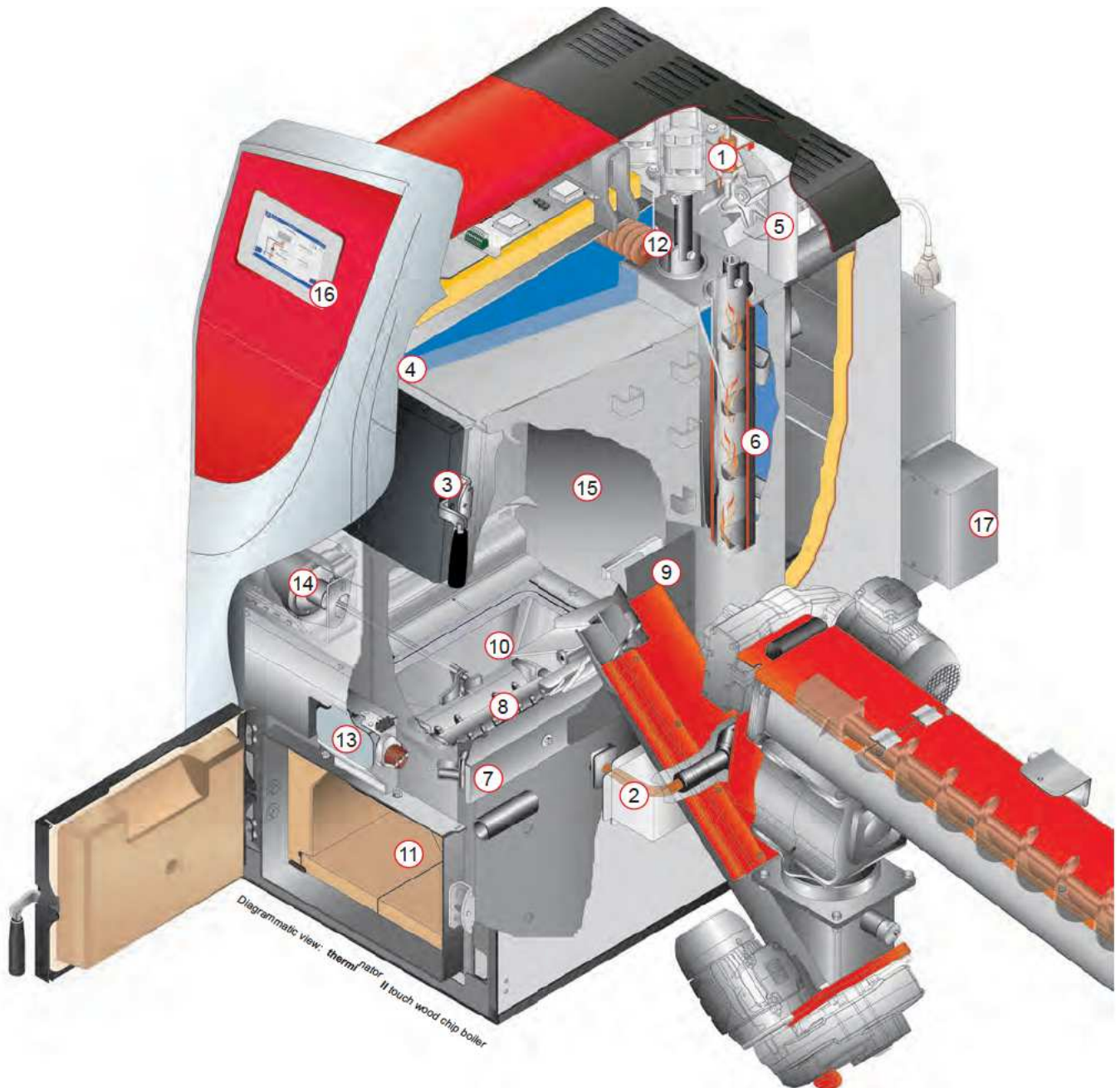

Legend:

- | | | | |
|---|---|----|---|
| 1 | Lambda sensor | 10 | Funnel grate |
| 2 | Autom. ignition via hot air fan | 11 | Generous ash chamber |
| 3 | Filling door | 12 | Back-up battery |
| 4 | Safety temperature limiter (STB) | 13 | Secondary air control with servomotor |
| 5 | ID fan | 14 | Fully automatic cleaning of the stainless steel grate |
| 6 | Heat exchanger cleaning | 15 | Stainless steel filling chamber |
| 7 | Primary air control | 16 | Control <i>eco</i> manager-touch |
| 8 | Grate | 17 | Fly ash box |
| 9 | Flange for automatic feeding
(optionally either left or right) | | |

Makes heating fun – Wood gasification technology with the highest levels of efficiency
30 years experience in the development of wood burning boilers provides you with a perfectly proven product.

Wood chips + log wood

- The unique design of the **thermiⁿator II** touch allows you to burn wood chips + log wood in one combustion chamber.
- Wood gasification technology without additional costs.

Perfect combustion technology

- Perfect combustion through downfiring combustion technology combined with the lambda sensor and the electronically controlled ID fan enables maximum efficiency with minimum emission values.
- So saving both your wallet and our environment.

Ash chamber

- The large ash chamber lengthens the intervals for emptying of the ash.
- Individually mounted fireclay bricks are service-friendly and ensure a long service life for the high-temperature combustion chamber.

Control

- Intuitive touch screen control **eco^{manager-touch}**.
- The latest control concept with user-friendly operation controls your boiler in terms of performance and firing.

Heat exchanger cleaning

- Reamers clean the walls of the heat exchanger in pre-set intervals. Raising the flue gas temperature results in a loss of efficiency. A clean heat exchanger saves fuel!
- **AUTOMATIC** means **AUTOMATIC!** A constant level of efficiency saves energy costs. No manual after-cleaning needed. Maintenance-free.

Automatic ignition

- The boiler is equipped with a fully automatic ignition.
- This means: The ignition is not only fully automatic at the time predefined by you in automatic operation with wood chips, but also if you fill the boiler with logs.

Embers preservation

- Option to select the function "Embers preservation".
- Any residual embers remain in the combustion chamber on the hopper grate for a certain period of time, which facilitates the heating up process once they have burned away entirely.

Low power operation

- The latest control concept with user-friendly operation controls your boiler in terms of performance and firing. Minimum power consumption - 230 V supply.
- Minimal electrical consumption - only 230W/h at max. capacity.

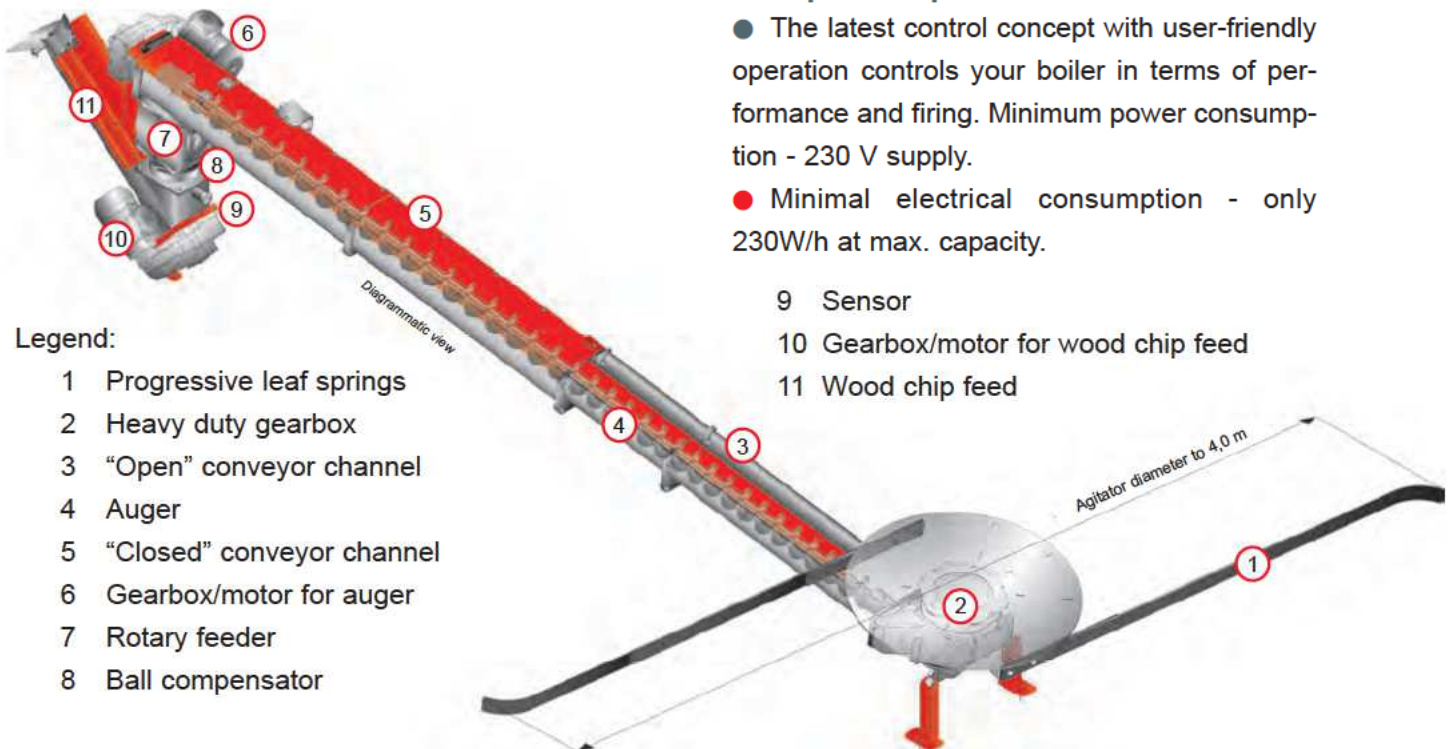

Legend:

- 1 Progressive leaf springs
- 2 Heavy duty gearbox
- 3 "Open" conveyor channel
- 4 Auger
- 5 "Closed" conveyor channel
- 6 Gearbox/motor for auger
- 7 Rotary feeder
- 8 Ball compensator

- 9 Sensor
- 10 Gearbox/motor for wood chip feed
- 11 Wood chip feed

● TECHNOLOGY ● BENEFIT

Sophisticated technology in detail

Generous stainless steel filling chamber

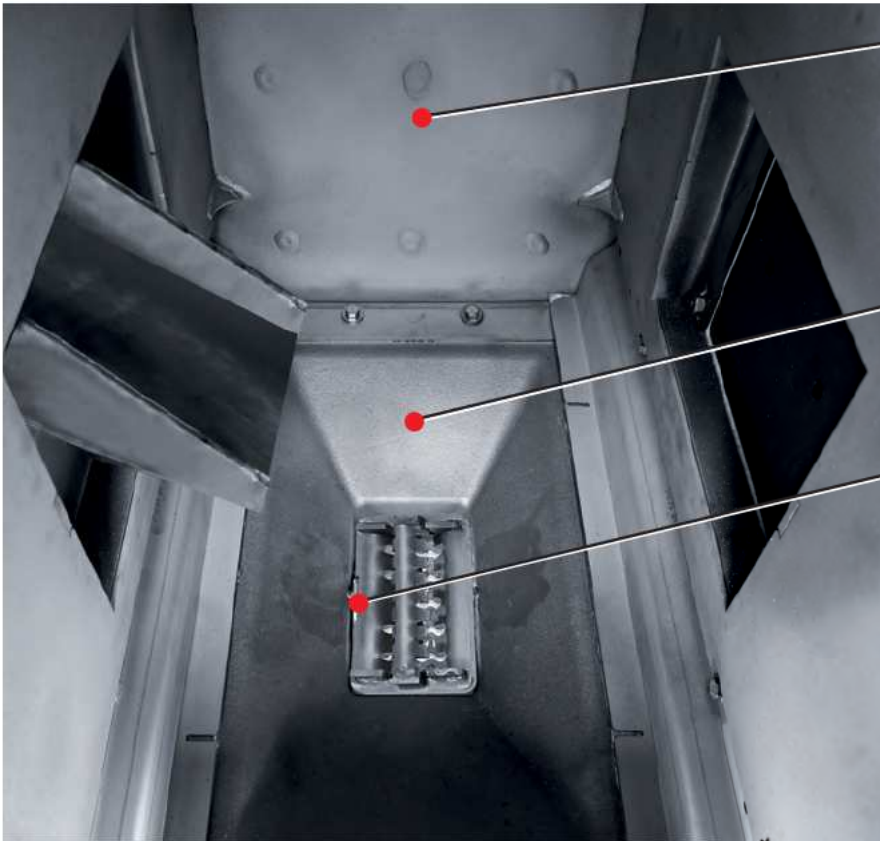

Generous stainless steel filling chamber

Allows heating wood chips and log wood in a single combustion chamber. 10-year warranty maintenance contract according to the filling chamber.

Funnel grate

The wood chips fall from above into the patented, funnel-shaped chromium steel cast grate.

Fully automatic cleaning of the grate

The purpose of the vibrating motor is to automatically clean the stainless steel grate.

Gasifier technology

Complete burning by top flame temperatures about 1.200°C.



Lambda sensor

Experience with lambda technology since 1981. Guarantees energysaving combustion through adjustment to the fuel.



Heat exchanger cleaning

Turbulators with flow-optimised guide plates clean the heat exchangers automatically and ensure low flue gas temperatures.

Rotating scraping edge

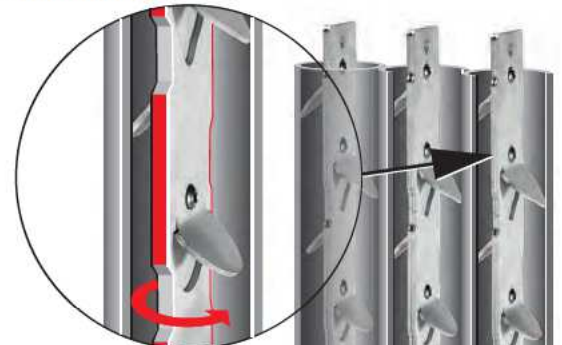

Flow-optimised guide plates

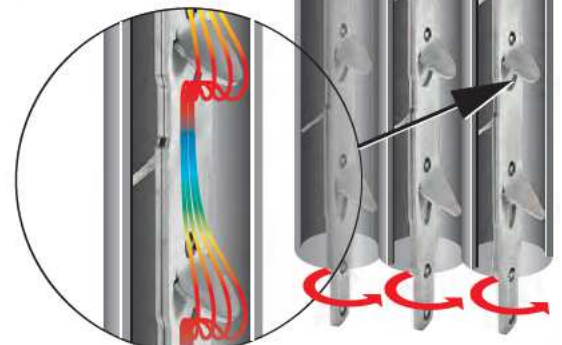



Automatic ignition (2)

The boiler is automatically ignited by a hot air fan at the times you set. Requirement: Request from heating circuit control system.



Induced draft fan (5)

The combustion air needed in the various areas is sucked in by the speed-controlled induced draft fan. It is controlled by the microprocessor which is built into the control system by the measuring values determined by the lambda sensor.



Generously dimensioned ash chamber (11)

In the **thermiⁿator II touch** we have placed emphasis on designing a particularly generous ash chamber, in order to achieve longer emptying intervals. The high temperature fireclay bricks are individually mounted in the combustion chamber.



Backup battery (12)

The backup battery prevents overheating in log wood mode in the event of a power failure.



Secondary air regulator with servo motor (13)

Air is fed in to the flame tips as required through the secondary air flap. This makes it possible to burn different biomass fuels while achieving excellent emissions values (especially when the operating conditions are modulated. The air quantities are preset by the Lambda sensor.



Fully automatic cleaning of the stainless steel grate (14)

Flange-mounted on the boiler side opposite the ignition fan. The vibrating motor transfers vibrations to the stainless steel grate in adjustable time intervals (approx. 50 vibrations per second) and cleans this automatically. The connection is established via the boiler power element.



Fully automatic cleaning of the stainless steel grate (17)

Flange-mounted on the boiler side opposite the ignition fan. The vibrating motor transfers vibrations to the stainless steel grate in adjustable time intervals (approx. 50 vibrations per second) and cleans this automatically. The connection is established via the boiler power element.

Conveyor technology

Agitator (1)

The flat-steel agitator carries the wood chips to the room extraction auger conveyor. Progressive leaf springs guarantee efficient emptying of the wood chip storage room. The heavy duty gearbox, which was specially developed for wood chips has an output side braking load of over 27,000 Nm. It is particularly sturdily built and dust-tight to ensure permanent trouble-free operation. The agitator diameter can be matched to the spatial requirements from 2 to 4 metres in 1/2 metre steps.

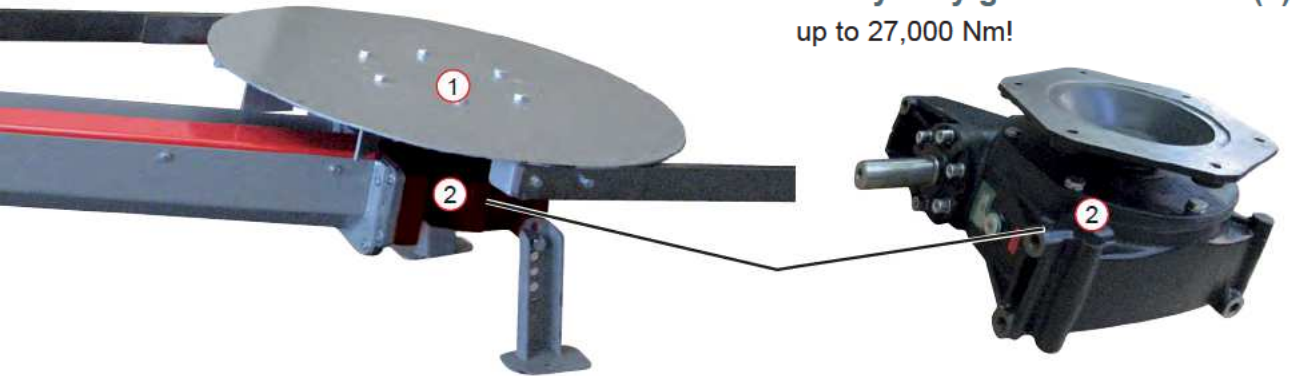

Heavy-duty gearbox loadable (2)
up to 27,000 Nm!

Auger/drive unit (3)

The drive unit comprises a spur gear (480Nm) and drive motor (230V), which drives the auger, which is directly connected to the heavy-duty gearbox at the agitator.

Roller link chain (4)

With the direct room extraction system, the rotary feeder is driven by a roller link chain from the drive unit. With downpipe extraction, the rotary feeder is driven by its own drive unit.

The rotary feeder (5)

is one of the most important safety devices in the boiler. The 4-chamber system separates the wood chip feed from the combustion chamber. It guarantees 100 percent burn-back safety in all operating circumstances.

The angle compensator (6)

enables simple adjustment of the auger. The completely metal ball joint has an inclination angle of $\pm 21^\circ$ and a swivel range of 360° .

Dust-insensitive sensor (7)

for the wood chip feed ensures controlled wood chip feed.

Automatic extinguishing device (8)

The automatic extinguishing device may be legally mandatory in some countries.



Charging and storage options

Direct room extraction system

Charging with front loader, tipper or rear shovel

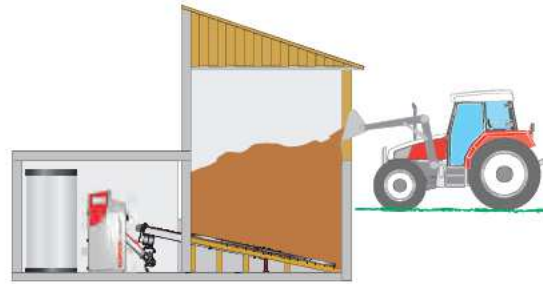

Direct room extraction system

- ✓ convenient
- ✓ no rebuilding necessary
- ✓ nearly complete filling

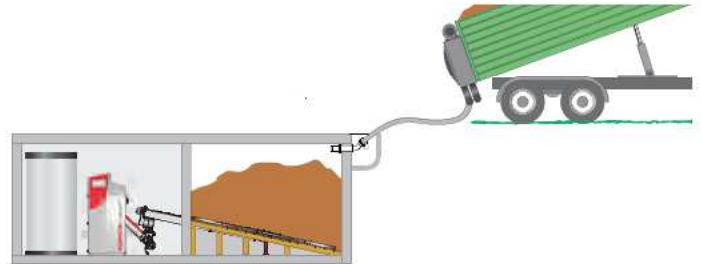

Direct room extraction system with auger

- ✓ for difficult to access cellar spaces

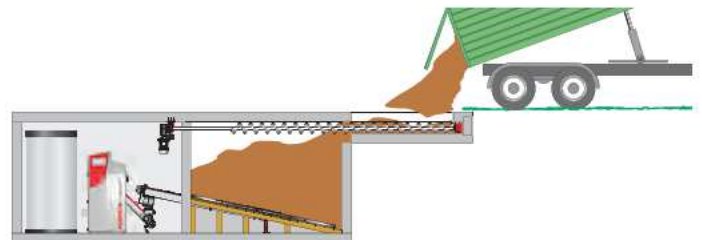

Room extraction system with lifting auger

- ✓ to overcome height differences
Max. length 12 m, max. angle 21°

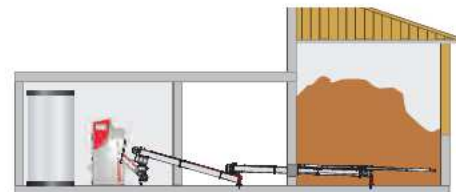

Downpipe room extraction

Charging with front loader, tipper or rear shovel

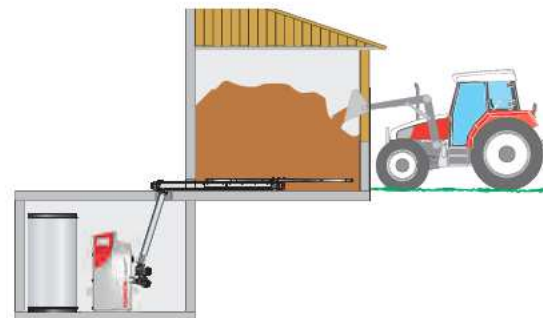

Downpipe room extraction

- ✓ if the storage room lies above the boiler room

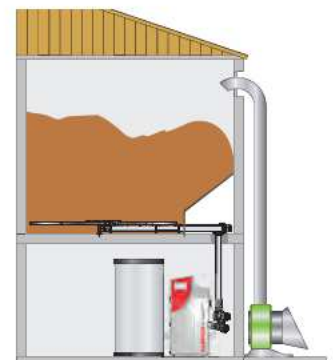

Intelligent control

Everything under control with **eco**^{manager-touch}





The core of your heating system the intelligent control *eco*manager-touch

To meet your daily comfort requirements, the controller is particularly important. The user determines when the heating comes on and how warm it should be.

- 7" VGA colour touch display: Guarantees simple, logical operation. Powerful microprocessor with power-saving standby mode.
- 1 weather-controlled heating circuit
3-point heating circuit curve, up to 8 modules are possible (option).
- 1 DHW tank charging circuit, up to 4 modules are possible (option).
- Fresh water module controllable with or without recirculation pump (option).
- 2 x three-circuit or 4 x two-circuit solar controllers possible (option). Also suitable for high-efficiency pumps.
- **mySOLARFOCUS** app: App for smartphone (Android and Apple) with attractive design for intuitive operation of the main heating parameters, such as room and flow temperature incl. heating times. Possibility to visualise the solar yield with installed heat quantity meter and control via *eco*manager-touch
- **Weatherman** function: Takes the weather forecast for the system's location into consideration. In conjunction with a solar-thermal system, prevents uneconomical start of the boiler when the weather forecast is good.

*eco*manager-touch

helps you to measure and control!

Changing outdoor temperatures have to be taken into consideration as precisely as very personal living habits. If the boiler is used in combination with a solar energy system, the burner only starts when the required heating energy cannot be fully provided by the solar energy system. This prevents any uneconomical boiler starts.

The *eco*manager-touch is very easy to use. It enables individual settings and ensures a perfectly tailored heating system.



Weather-depending control + mySOLARFOCUS app

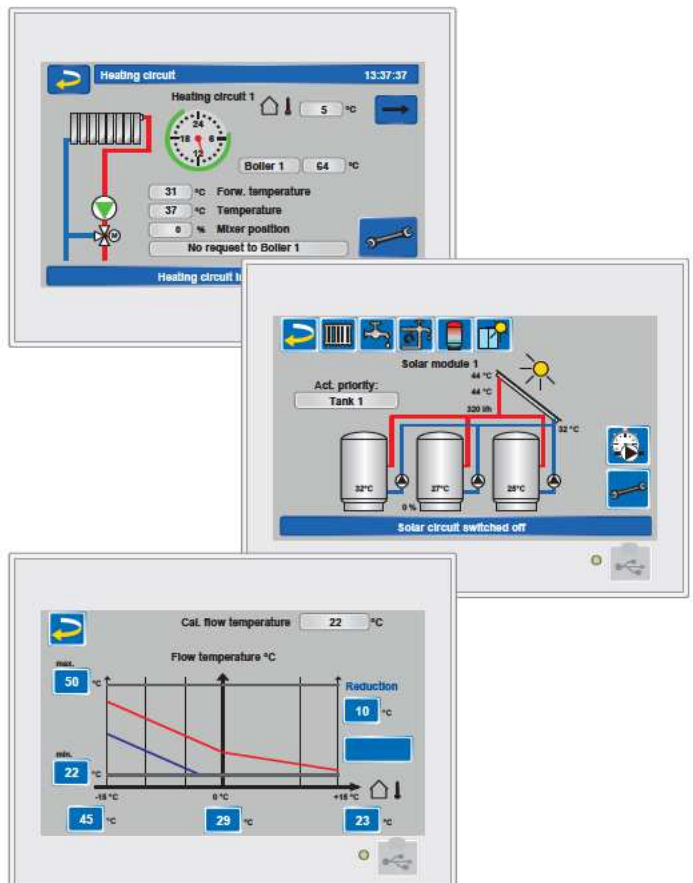

Perfectly combined with solar plant

thermiⁿator II touch
with stratified buffer storage tank
and fresh water module

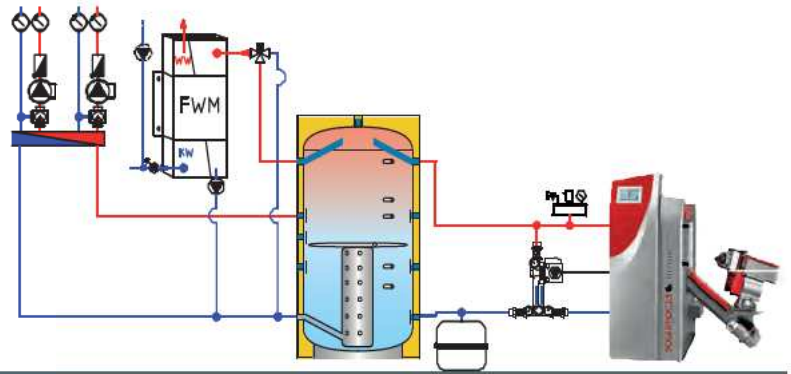

thermiⁿator II touch with HYKO storage tank
and solar plant

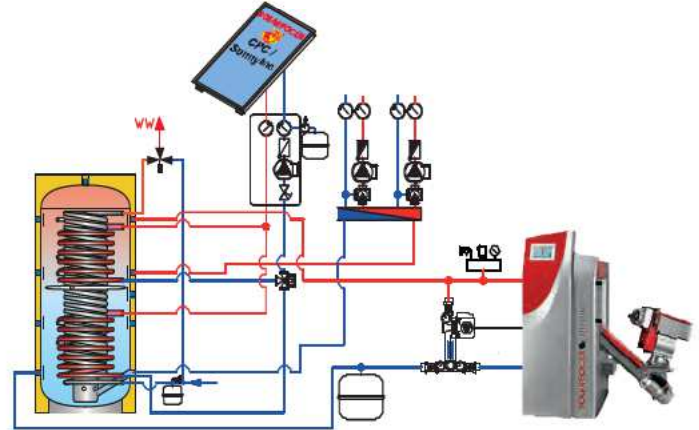
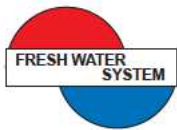

thermiⁿator II touch
with stratified buffer storage tank,
stratified load module,
fresh water module and solar plant

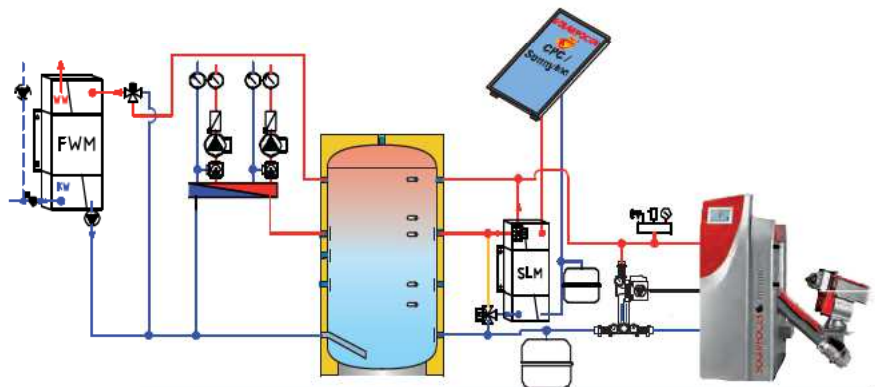

thermiⁿator II touch
with stratified buffer storage tank,
drinking water storage tank and solar plant

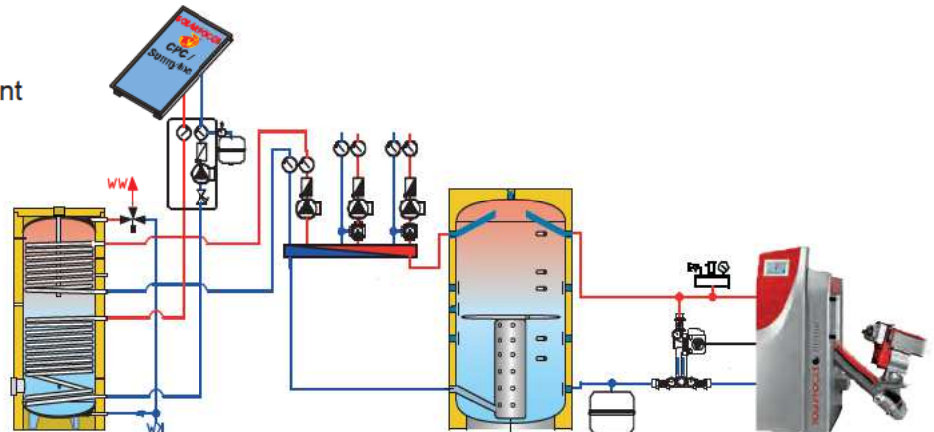

More hydraulic schemes
are available - we can help
you by planning!

Buffer storage tank

- For automatic boilers also, SOLARFOCUS recommends installing a buffer storage tank
- Better adjustment to the heat load required
- The boiler runs continually in optimum operation
- Minimises boiler starts
- Extends the life cycle of your boiler
- Can be perfectly combined with solar plants



INNOVATION - ECONOMY – QUALITY

SOLARFOCUS shapes the future with products that serve mankind and protect the environment.

SOLARFOCUS is committed to researching, developing, manufacturing and selling environmental technology in the fields of:

Biomass heating,
Solar systems,
Storage technology and
Fresh water technology

SOLARFOCUS are one step ahead: The research, development and cooperation with research institutes and prestigious partners has led to our dynamic development. Our products are on offer throughout Europe. The courses and seminars held on a permanent basis with our partners guarantee personalised advice and professional installers for you.

AWARDS:

- Young entrepreneur's Award
- Innovations Award 1995
- Pegasus in Gold
- Environmental Protection Award of the Upper Austrian Region
- Innovation Award "EnergieGenie" 2003
- House Technology Award 2004
- Innovation Award "EnergieGenie" 2011
- Italian innovation prize for energy-efficient technologies 2012
- Polish Innovation Award „Zloty Medal" 2012 and 2013
- Slovenian Innovation Award „Energetika" 2014
- Best Business Award 2014
- UK Built It Award 2015
- Innovation Award "EnergieGenie" 2016

and many more confirm our philosophy.



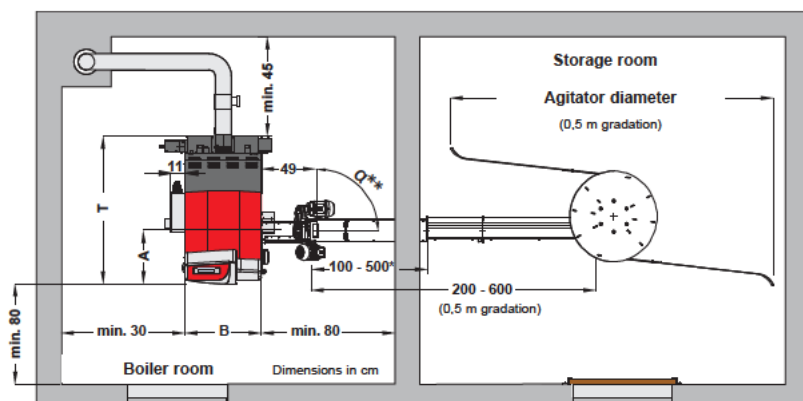

thermi ^{nator} II touch		30	40	49	60
Power	[kW]	30	40	49	59
Depth without ID fan	[cm]	117	130	151	151
Total width (T)	[cm]	126	136	158	158
Width without ignition (B)	[cm]	62	67	83	83
Position of insertion (A)	[cm]	47	47	59	52
Height incl. adjustable feet***	[cm]	155	166	167	167
Minimum room height****	[cm]	168	186	186	186
Flue pipe DM	[cm]	13	15	20	20
Height of flue pipe center***	[cm]	78	88	90	90
Weight	[kg]	564	687	817	817
Water content	[l]	90	126	188	188
Filling chamber volume	[l]	145	186	290	290
Max. length of logs	[cm]	56	56	66	66
Filling chamber door	[cm]	34 x 24	39 x 24	54 x 24	54 x 24
Backup battery	["]	OT 1/2"	OT 1/2"	OT 1/2"	OT 1/2"
Thermowells for temperature sensor	["]	IT 1/2"	IT 1/2"	IT 1/2"	IT 1/2"
Exhaustion	["]	OT 1/2"	OT 1/2"	OT 1/2"	OT 1/2"
Boiler return	["]	OT 5/4"	OT 5/4"	OT 6/4"	OT 6/4"
Boiler flow	["]	OT 5/4"	OT 5/4"	OT 6/4"	OT 6/4"
Recommended buffer tank volume	[l]	1.500	2.000	2.500	3.000

* Covered length ** Installation angle α from 0° up to 180° *** Adjustable feet at maximum depth of thread **** The minimum room height is required for maintenance work

Everything from one supplier

Solar systems – Biomass heating – Storage technology – Fresh water technology

Tested leading-edge technology – EN ISO 9001 certified



Your specialised dealer

SOLARFOCUS GmbH, Werkstrasse 1, A-4451 St. Ulrich/Steyr
 e-mail: office@solarfocus.com Tel.: +43 (0) 7252 / 50 002 - 0
 web: www.solarfocus.com Fax: +43 (0) 7252 / 50 002 - 10